



Product Summary

$V_{(BR)DSS}$	$R_{DS(on)TYP}$	I_D
100V	1.2m Ω @10V	325A

Feature

- Split Gate Trench Technology
- Low $R_{DS(ON)}$
- Low Gate Charge
- Low Gate Resistance
- 100% UIS Tested

Application

- Power Switching Application
- Motor Driving

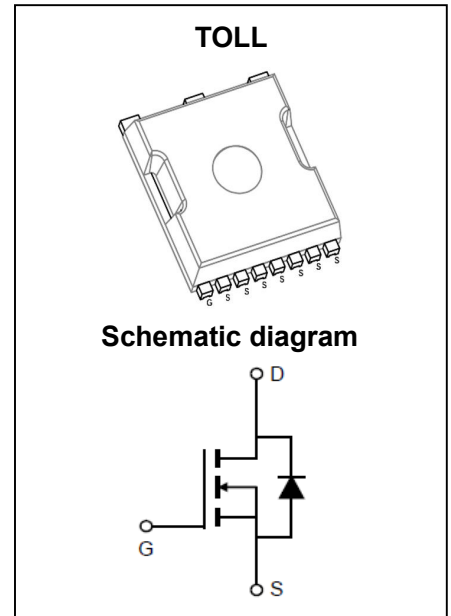

Package Marking and Ordering Information

Part Number	Package	Marking	Packing	Reel Size	Tape Width	Qty
GPT012N10NTP	TOLL	T012N10N	Reel & Tape	330mm	24mm	2000pcs

ABSOLUTE MAXIMUM RATINGS ($T_A = 25^\circ\text{C}$ unless otherwise noted)

Parameter	Symbol	Value	Unit	
Drain - Source Voltage	V_{DS}	100	V	
Gate - Source Voltage	V_{GS}	± 20	V	
Continuous Drain Current ¹	$T_C = 25^\circ\text{C}$	I_D	325	A
	$T_C = 100^\circ\text{C}$	I_D	205	A
Pulsed Drain Current ²	I_{DM}	1300	A	
Single Pulsed Avalanche Current ³	I_{AS}	99	A	
Single Pulsed Avalanche Energy ³	E_{AS}	2450	mJ	
Power Dissipation ⁵	$T_C = 25^\circ\text{C}$	P_D	500	W
Thermal Resistance from Junction to Ambient ⁶	$R_{\theta JA}$	35	$^\circ\text{C}/\text{W}$	
Thermal Resistance from Junction to Case	$R_{\theta JC}$	0.2	$^\circ\text{C}/\text{W}$	
Junction Temperature	T_J	150	$^\circ\text{C}$	
Storage Temperature	T_{STG}	-55~ +150	$^\circ\text{C}$	

MOSFET ELECTRICAL CHARACTERISTICS ($T_A = 25^\circ\text{C}$ unless otherwise noted)

Parameter	Symbol	Test Condition	Min	Type	Max	Unit
Off Characteristics						
Drain - Source Breakdown Voltage	$V_{(BR)DSS}$	$V_{GS} = 0V, I_D = 250\mu A$	100			V
Zero Gate Voltage Drain Current	I_{DSS}	$V_{DS} = 100V, V_{GS} = 0V$			1	μA
Gate - Body Leakage Current	I_{GSS}	$V_{GS} = \pm 20V, V_{DS} = 0V$			± 100	nA
On Characteristics⁴						
Gate Threshold Voltage	$V_{GS(th)}$	$V_{DS} = V_{GS}, I_D = 250\mu A$	2	3.1	4	V
Drain-source On-resistance	$R_{DS(on)}$	$V_{GS} = 10V, I_D = 20A$		1.2	1.6	$m\Omega$
Dynamic Characteristics						
Input Capacitance	C_{iss}	$V_{DS} = 50V, V_{GS} = 0V, f = 0.1MHz$		13862		pF
Output Capacitance	C_{oss}			2046		
Reverse Transfer Capacitance	C_{rss}			45		
Gate Resistance	R_g	$V_{DS} = 0V, V_{GS} = 0V, f = 0.1MHz$		2.8		Ω
Switching Characteristics						
Total Gate Charge	Q_g	$V_{DS} = 50V, V_{GS} = 10V, I_D = 20A$		200		nC
Gate-source Charge	Q_{gs}			58		
Gate-drain Charge	Q_{gd}			42		
Turn-on Delay Time	$t_{d(on)}$	$V_{DD} = 20V, V_{GS} = 10V, R_L = 1\Omega, R_G = 3\Omega$		39		ns
Turn-on Rise Time	t_r			65		
Turn-off Delay Time	$t_{d(off)}$			129		
Turn-off Fall Time	t_f			90		
Source - Drain Diode Characteristics						
Diode Forward Voltage ⁴	V_{SD}	$V_{GS} = 0V, I_S = 20A$			1.2	V

Notes :

- 1.The maximum current rating is limited by package.And device mounted on a large heatsink
- 2.Pulse Test : Pulse Width $\leq 10\mu s$, duty cycle $\leq 1\%$.
- 3.EAS condition: $V_{DD} = 50V, V_{GS} = 10V, L = 0.5mH, R_G = 25\Omega$ Starting $T_J = 25^\circ\text{C}$.
- 4.Pulse Test : Pulse Width $\leq 300\mu s$, duty cycle $\leq 2\%$.
- 5.The power dissipation P_D is limited by $T_{J(MAX)} = 150^\circ\text{C}$.And device mounted on a large heatsink
- 6.Device mounted on $1in^2$ FR-4 board with 2oz. Copper, in a still air environment with $T_A = 25^\circ\text{C}$.

Typical Characteristics

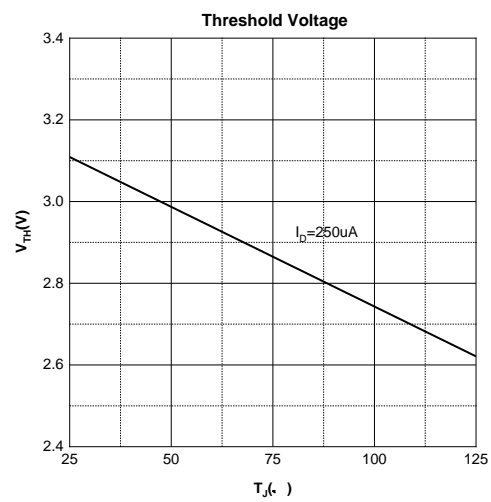
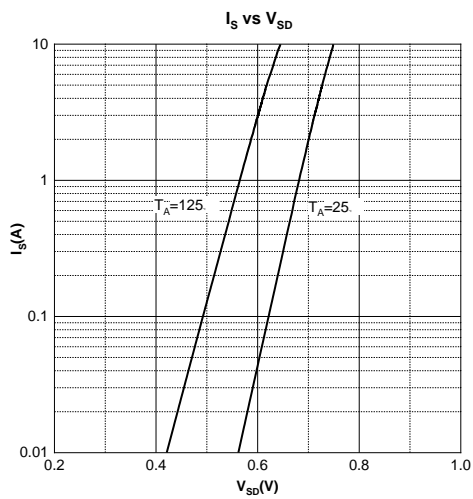
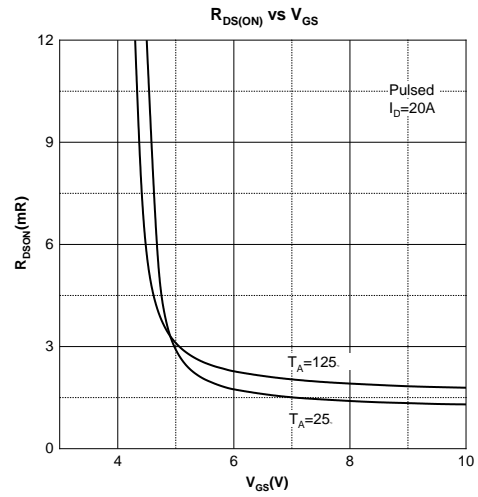
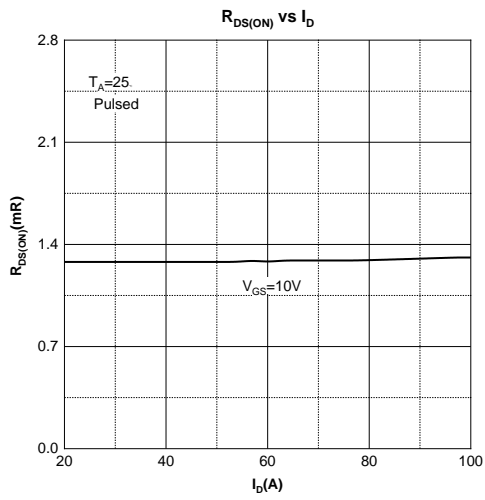
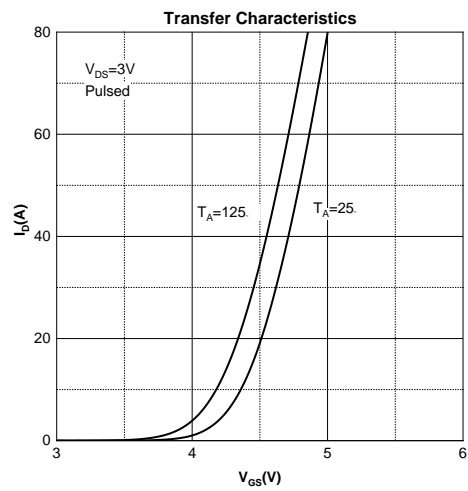
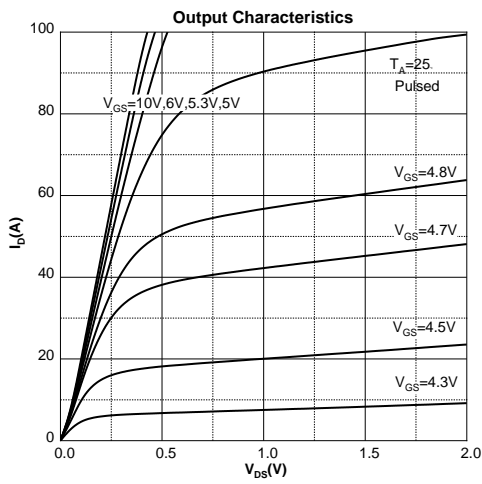

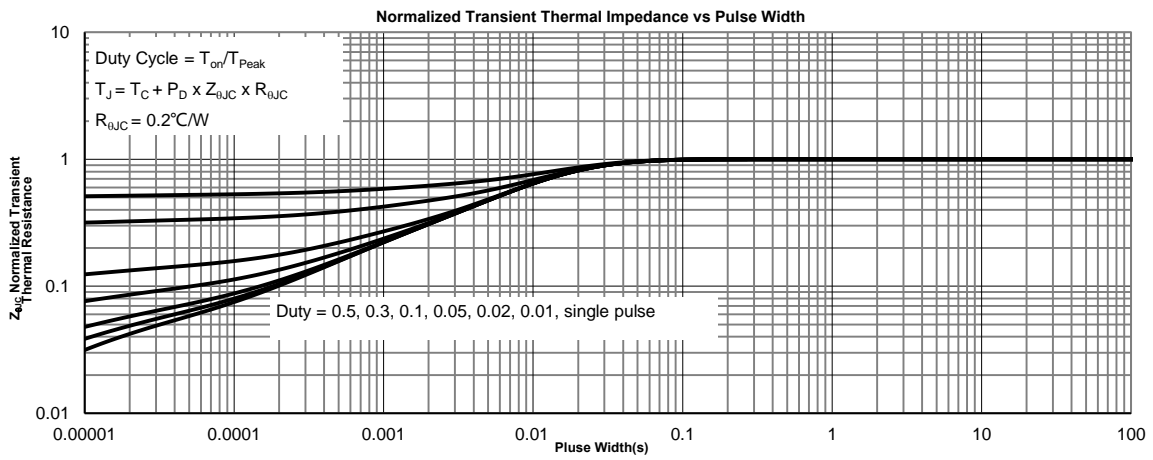
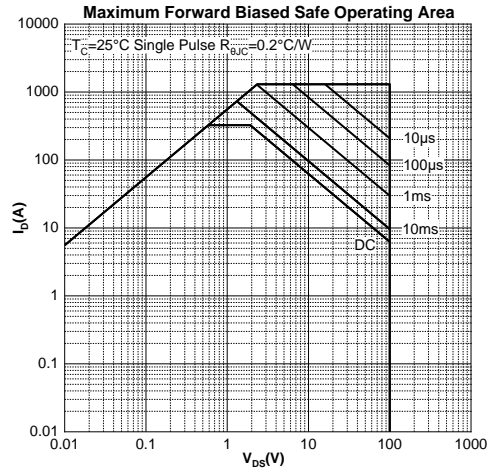
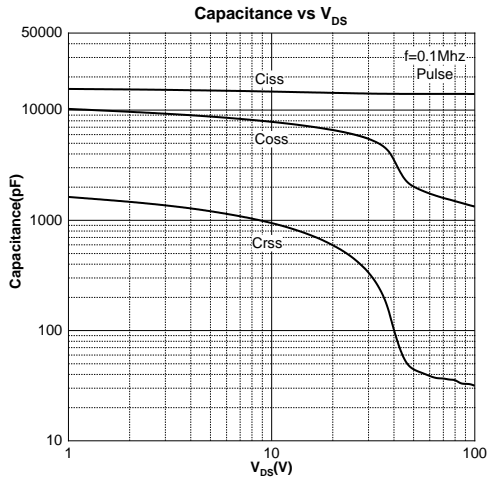

Gate Charge Test Circuit & Waveform

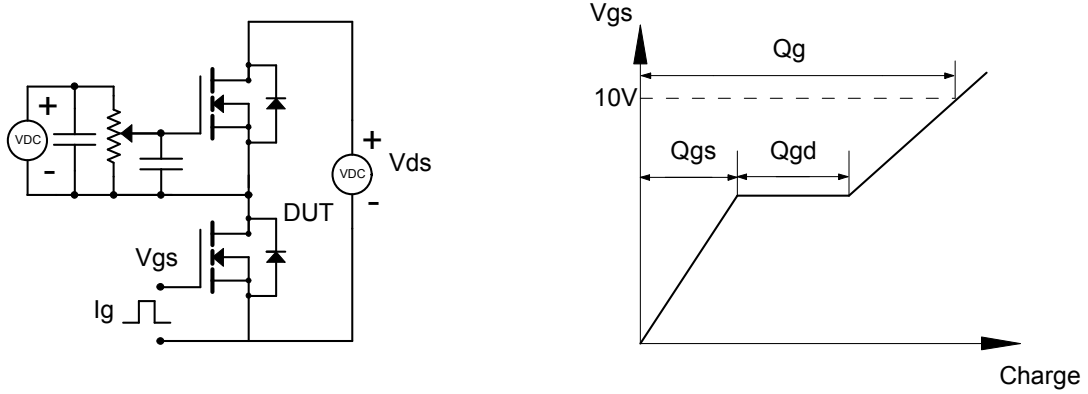

Resistive Switching Test Circuit & Waveform

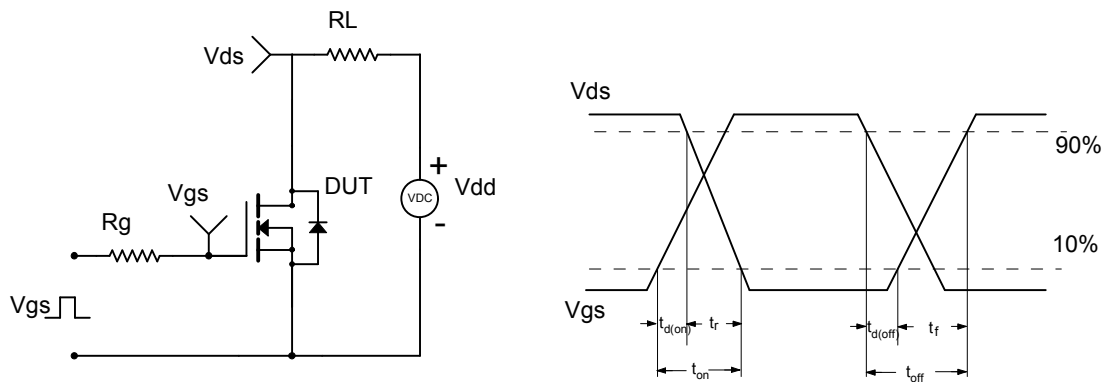

Unclamped Inductive Switching (UIS) Test Circuit & Waveforms

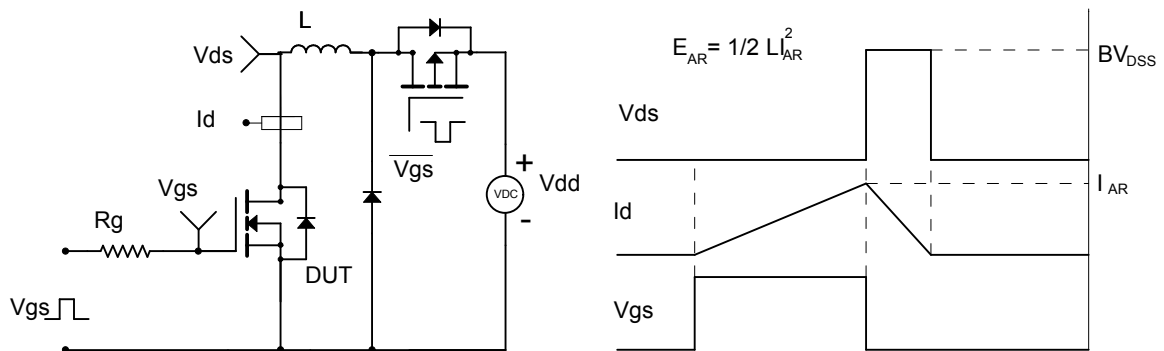

TOLL Package Information

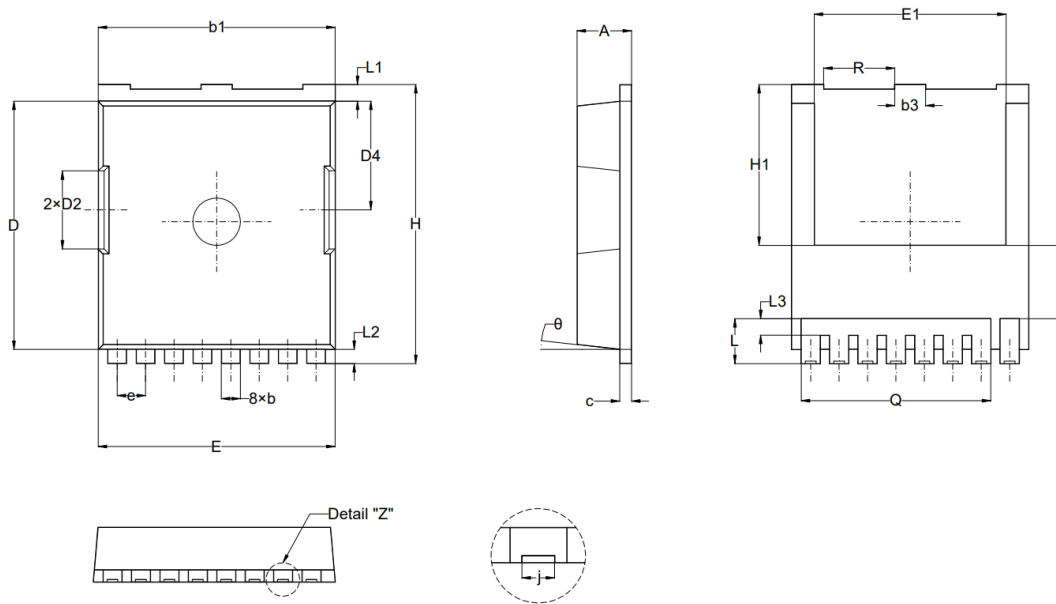

SYMBOL	MILLIMETER		Dimensions In Inches	
	MIN.	MAX.	Min.	Max.
A	2.200	2.400	0.087	0.094
b	0.650	0.900	0.026	0.035
b_1	9.700	9.900	0.382	0.390
b_3	1.150	1.350	0.045	0.053
c	0.400	0.600	0.016	0.024
D	10.280	10.480	0.405	0.413
D_2	3.200	3.400	0.126	0.134
D_4	4.450	4.650	0.175	0.183
E	9.800	10.000	0.386	0.394
E_1	7.900	8.300	0.311	0.327
e	1.200BSC		0.047BSC	
H	11.480	11.880	0.452	0.468
H_1	6.950REF		0.274REF	
j	0.350REF		0.014REF	
K	3.00REF		0.118REF	
L	1.600	2.000	0.063	0.079
L_1	0.550	0.850	0.022	0.033
L_2	0.500	0.700	0.020	0.028
L_3	0.500	0.800	0.020	0.031
N	8REF		0.315REF	
Q	8REF		0.315REF	
R	2.800	3.200	0.110	0.126
θ	10°REF			